

Otonabee-South Monaghan an OSM Township

P.O. Box 70, 20 Third Street, Keene, Ontario K0L 2G0

Tel: 705-295-6852 • Toll Free 705 area code only: 800-999-4861 • Fax: 705-295-6405
info@osmtownship.ca • www.osmtownship.ca • Facebook & Twitter @OSMTownship

NEWSLETTER

SUMMER/FALL 2023

Property Tax

Property taxes fund Education, the County of Peterborough and the Township.

For residential ratepayers, the taxes paid to the Township are shared as follows:

- Education 17%
- County 32%
- Township 51%

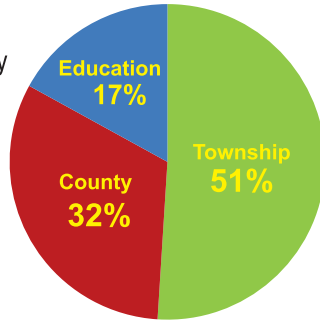

2023 Final Tax Bill Due Dates

Friday July 28 & Friday Sept 29

Please note that a 1.25% penalty is imposed on unpaid balances on the 1st day of each and every month the default continues. Township Staff do not have the authority to waive penalties.

Flat rates for Area Services on the Tax Bill

Annual Rate for:

- * Curbside Pick Up (island and vacant lands excluded)
\$53.00 per household and/or unit
- * For owners of properties served by the Municipal Water Systems in Keene and Stewart Hall \$2,244.00 per household
- * For Burnham Meadow property owners served by sewer systems:
\$1,139.00 per household and/or unit
- * Swimming Pool Surcharge
\$114.00 per household in Keene and Stewart Hall
- * Street Light Service Areas are rated by community area

Payments

Payment options are listed on the reverse side of your tax bill as well as on the Township website at www.osmtownship.ca under "Payment Options" or please call or visit the Township office for more information. Pre-authorized payment plans are available. If paying through internet banking, please allow 2-3 business days for us to receive payment to ensure your payment is not received late. You can also pay by credit card online through Paymentus.

Property Tax Grant for low-income seniors and persons with disabilities

If you are a senior on the guaranteed income supplement or a person on a disability pension, you may qualify for a property tax grant. This grant covers permanent year round residences only. The County of Peterborough runs the program and it is administered by the Township. Proof of eligibility is required. Applications will be available on our website and in the office by approximately the end of September and must be submitted by November 15, 2023.

Budget 2023

The **2023 Total Township Budget** is \$14,588,847 which includes operating costs of \$7,926,176, capital plan projects of \$4,918,199 and \$1,744,472 provision for reserves to fund future infrastructure replacement. The **2023 Total Township Tax Levy** is \$6,859,186 with the balance funded through grants, user fees, development charges, reserve transfers and other revenue.

This translates into a 2.79% increase in the Township tax rate. Each property is impacted differently based on the assessed value determined by the Municipal Property Assessment Corporation. Assessment increases are generally phased in over four years. For more information about assessment, please check out the MPAC website at www.mpac.ca. To find out more about your particular property assessment, register online at www.aboutmyproperty.ca. A breakdown showing any assessment-related tax increase is provided on every tax bill.

Building Department

In the coming weeks, we are implementing the on-line Cloud and Planning Permit process to make the application and communication process more modern.

When considering a renovation, alteration, addition, new build, swimming pool and adding a secondary suite please call the Building Department at 705-295-6852 ext 233 to discuss the details of your project. We can answer any questions that would relate to applying for a building/renovation permit, help with the requirements for drawings, zoning, septic systems setbacks and Otonabee Conservation approval.

Building permits are required for the following:

- Additions, renovation, or alteration to a house, adding a secondary suite
- New industrial, commercial, and institutional buildings
- Making new openings
- Swimming pool
- Decks, fireplaces, adding plumbing fixtures, finishing a basement
- Tents greater than 60 sq m (646 sq.ft.) in ground area (including multiple tents)
- Demolition of part or whole structures

Building permits are **NOT** required for the following:

- Roof re-shingling
- Replacement of existing, same-size windows and doors, hot water tank, furnace
- Replacing exterior siding
- Minor Interior renovations such as replacing cabinetry
- Accessory shed under 15 sq.m (161 sq.ft.) but must conform to zoning setbacks



For a more complete list and additional information visit our website at www.osmtownship.ca.

Development Charges for 2023

The 2023 phased in Township Development Charges under By-Law No. 2020-60 are as follows:

Residential – All dwelling units \$10,429

Non-Residential – Commercial Sector \$4.25/square foot

Note: The Township also collects development charges for the County of Peterborough, PVNCCDSB and KPRDSP Educational Boards (not included in the above prices).

News & Notices

Watch for details on community events and recreational registrations by following us on Twitter and Facebook at @OSMTownship.

All community news and events can also be found on our website at www.osmtownship.ca.

Running a community program or event? Submit the details to us by email at info@osmtownship.ca and your event may be promoted on our website, LED sign, Facebook or Twitter, provided it meets the Electronic Information (LED) Sign Policy.

Weekly Township News Bulletins are posted Monday mornings on our website as well as shared to social media. They highlight meetings, news, events and reminders.



DEPARTMENTS

Municipal Administration - 705-295-6852 / 1-800-999-4861

Chief Administrative Officer, Greg Borduas Ext. 214

Deputy CAO/Clerk, Heather Scott Ext. 223

Treasurer/Director of Finance, Sara Flaherty Ext. 211

Deputy Treasurer/Office Manager, Jackie Fitzgerald Ext. 216

Tax Inquiries - 705-295-6852

Accounting and Tax Clerk, Shannon Neto Ext. 210

Building Department - 705-295-6852

Director of Building Services (CBO), John Eisinga Ext. 222

Junior Planner, Emily Baker Ext. 232

Building Inspector, Steve Wigboldus Ext. 212

Building & Planning Assistant, Christine Zurosky Ext. 233

Parks & Recreation Department - 705-295-6862

Recreation, Parks & Facilities Manager, Mike Nelson

Public Works Department - 705-745-3595 - **Director of Public Works**, Craig Brooks

Dog Control - 705-939-6791 / 1-866-709-6083 - **Dog Control Officer**, Debra Haigh

Fire and Emergency Services - 705-295-6880

Fire Chief/CEMC, Chuck Parsons Ext. 217

Fire Admin/Public Education/Fire Prevention Officer, Cara Wood Ext. 215

COUNCIL MEMBERS

Mayor Joe Taylor 705-295-4886 mayor@osmtownship.ca

Deputy Mayor Bonnie Clark 705-295-4434 deputymayor@osmtownship.ca

Councillors -

at Large Mark Allen 705-295-1544 atlargecouncillor@osmtownship.ca

Otonabee Ward Nick Powers 705-875-8245 otonabecouncillor@osmtownship.ca

South Monaghan Ward

Terry Holmes 416-899-0740 southmonaghancouncillor@osmtownship.ca

Fire Department

Smoke Alarms are mandatory in all homes, on every level of the home and outside all sleeping areas.

Carbon Monoxide Alarms are required in homes with a fossil-fuel burning appliance, wood stove or attached garage and must be located outside of all sleeping areas



All alarms have an expiry date of 7-10 years, depending on manufacturer recommendations. Be sure to check the expiry date when you change the alarm batteries to ensure your alarms are current.

Plan and practice your **Escape Plan**.

Know 2 ways out of rooms.

Have a set meeting place outside.

Once you get out, Stay Out!

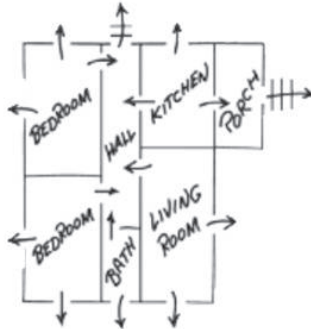

Burn Permits - Please be advised that OSM moved to an online burn permitting system effective January 1, 2023.

Owners of property in OSM, will need to create an account, and request the burn permit via the online system found at: osm.burnpermits.com



If you have trouble with the system or have questions about creating your account, please contact Cara Wood at the Fire Department Administration Office: 705-295-6880 Ext. 215 or by email: fireadmin@osmtownship.ca
An updated burning by-law has been adopted: **2022-50: Regulations for the Setting of Open-Air Fires.**

A copy of the by-law can be found within the burn permit system and on the Township website. Burn Permits are not required for campfires or recreational fires.

See the new by-law for details and rules for campfires and permit fires.

Burning in a barrel is not permitted in OSM.

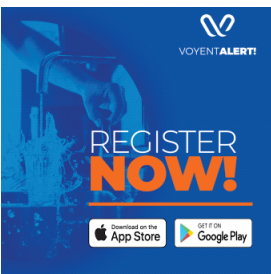

We are pleased to announce that we have chosen the Voyent Alert! Notification Service to keep you informed during emergencies as well as day-to-day notifications. Choose how you want to stay informed.

Receive emergency alerts or day-to-day notifications from OSM Township via Voyent Alert! mobile app, text/SMS, email or voice calling to a landline.

To ensure you are being reached during a crisis, we recommend registering for at least two of the channels.

Register here: <https://voyent-alert.com/ca/community/> or call the Fire Department Administration office if you require assistance registering for landline notification 705-295-6880.



Do you need a family doctor?

Register with Health Care Connect Today!

Health Care Connect is a provincial wait list connecting orphaned patients with a family doctor. You can register with the program by visiting www.ontario.ca/healthcareconnect or by calling 1-800-445-1822 from Monday to Friday from 9AM – 5PM.

Garbage and Recycling

OSM Transfer Station

1594 Drummond Line, 705-749-2331

Hours: Mon. & Fri. 1-6 pm / Wed. 9am - 6 pm

Sat. 9 am – 3 pm

Garbage Collection Inquiries/Missed Collection

Waste Connections Canada – 705-742-4268 or

Marilyn.jewer@wasteconnections.com

Or Stephen.bye@wasteconnections.com



Clear Garbage Bag Program. We thank all residents for helping to make this program a continued success. The Township is very pleased to report that since the launch of the program there has been a significant decline in waste generation and a huge increase in recycling. Garbage can be left at the curb or can be taken to the Drummond Line Transfer Station for a fee in the following ways: 1) in a clear bag in a garbage container; 2) in a clear bag; or 3) in an opaque small grocery size privacy bag to shield private items. **Garbage must be at the road before 7:00am to avoid missing collection.** For clear bag program details please see the Township website www.osmtownship.ca.

Peterborough County provides recycling services to all residents. The County of Peterborough website (www.ptbocounty.ca/recycling) has a Searchable Waste Portal to find information regarding recycling and garbage collection all in one place. On this site you will find a printable blue box sort guide that will assist you in finding the appropriate place for your recyclables.

Recycling Program - County of Peterborough

705-775-2737 or waste@ptbocounty.ca

For missed Collection call Emterra at 705-742-3139

Remember the Big Three when recycling:

1. **Have your blue boxes to the road by 7am.**
2. Sort your materials into 2 boxes, Containers and Papers.
 - Use as many boxes as needed, as long as Containers, and Papers are in separate boxes.
3. Keep recycling loose in Blue Boxes.
 - Bagged recycling will not be collected.

Special Provisions for Individuals with a Medical Condition

The Application for Medical (Non-Hazardous) Waste Exception – Curbside Waste Collection can be found at www.osmtownship.ca under Garbage & Recycling.

Recreation, Parks and Facilities

Parks and Conservation Areas

The Township boasts several parks and playgrounds for residents to enjoy. You can also visit Burnham Woods Provincial Park, Harold Town Conservation Area, Squirrel Creek Conservation Area, McIntyre Park or hike the Lang-Hastings Trail to connect with nature or to enjoy a picnic. For more information including locations visit our website www.osmtownship.ca

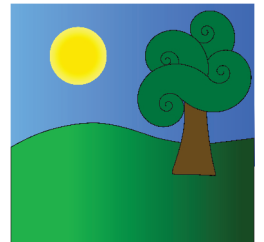

Otonabee Memorial Community Centre/Sports Fields/Facilities

We are pleased to announce that Phase 2 of the Otonabee Memorial Community Centre (OMCC) Revitalization Project is well underway. The project includes a new layout, six dressing rooms, new flooring, energy-efficient lighting, a fresh coat of paint, and new ceiling tiles. This project will help to ensure that our facility is accessible, up-to-date, functional, and equipped to meet the needs of our community. The OMCC is currently closed to the public and is scheduled to reopen September 15, 2023. To view availability and/or book this facility, or any other OSM rental space, see the information below. Book Online - Visit <https://app.universusrec.com/osmtownshippub/index> to set up an account. You can check availability, current rates, and make booking requests for all OSM rental spaces from one place. Call or Email – 705-295-6862 or recreationmanager@osmtownship.ca

Upcoming Summer and Fall Events and Updates:

- ✓ Public Skating – 2023/2024 Season begins September 21, 2023
- ✓ Minor Hockey Registration – Visit www.otonabewolves.com for more information.
- ✓ Youth Girls Hockey Registration – Visit www.keenewolverines.com for more information.
- ✓ Otonabee Skating Club Registration – Visit www.otonabeeskatingclub.ca for more information.

*Interested in Sponsoring Public Skating or Advertising opportunities for your business? Contact the Recreation, Parks, and Facilities department to learn more! recreationmanager@osmtownship.ca
Events and rental details can be found at www.osmtownship.ca under Recreation, Parks and Facilities.